

2.DG

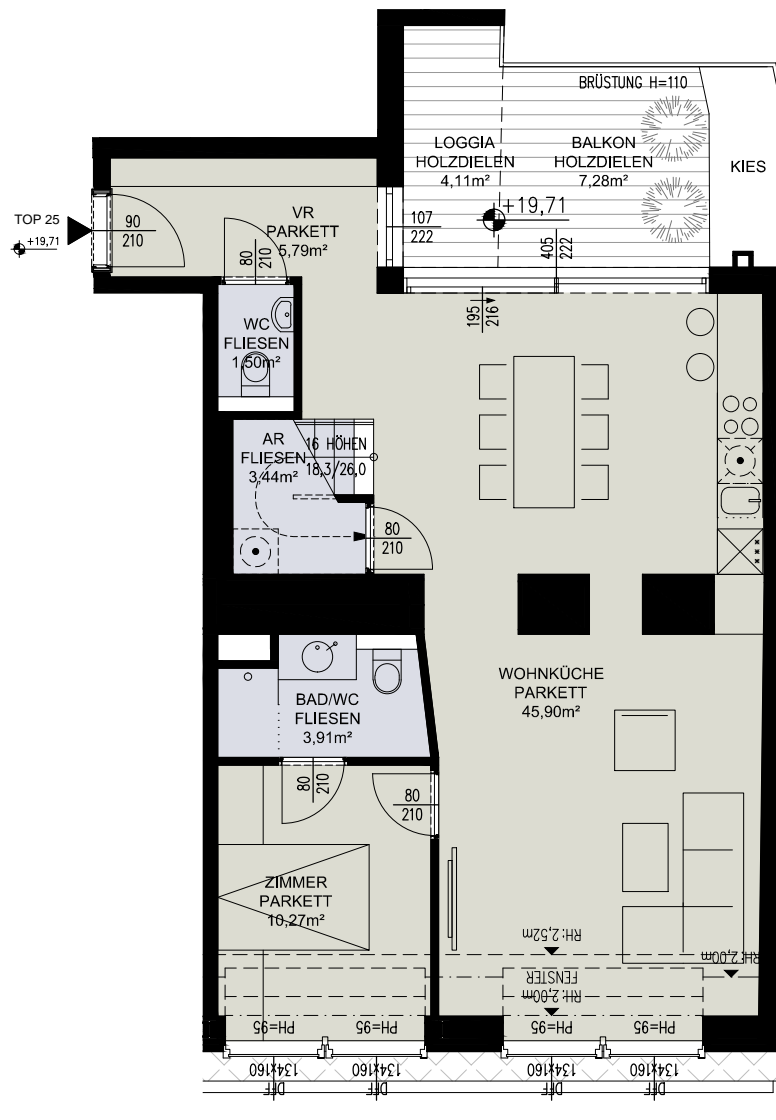

1.DG

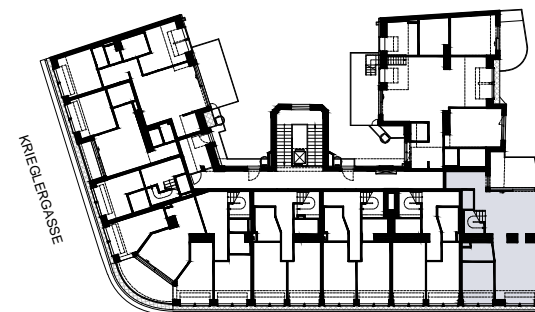

EINGANG
UNTERE WEISSGERBERSTRASSE

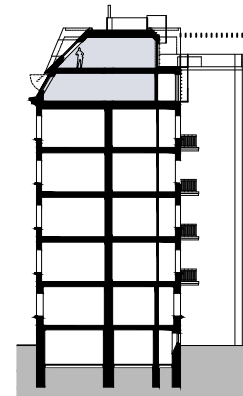

TOP 25

1. + 2. DACHGESCHOSS 3 ZIMMER

Wohnung ca. 114,15m²

Terrasse ca. 8,50m²

Loggia / Balkon ca. 11,39m²

Raumhöhe 1.DG ca. 2,52m

Raumhöhe 2.DG ca. 2,75m

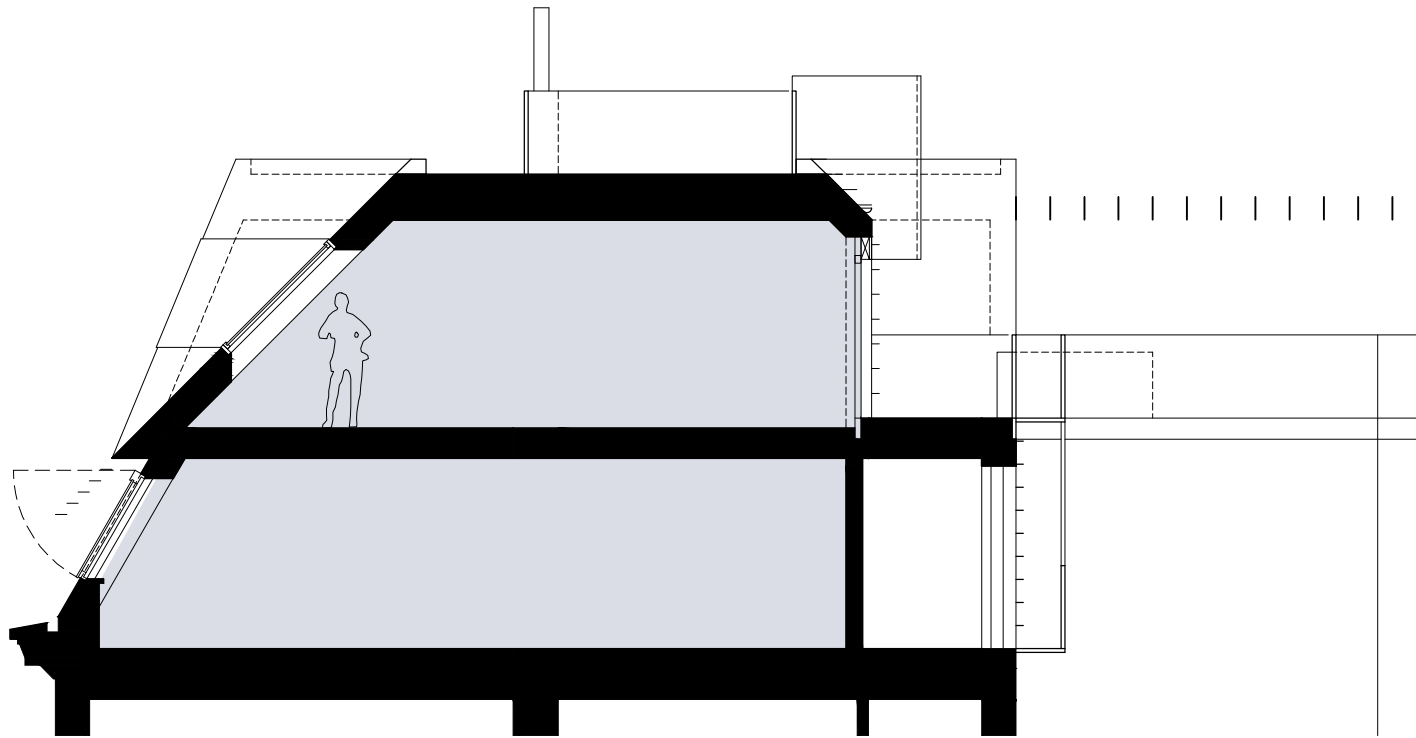

SCHNITT

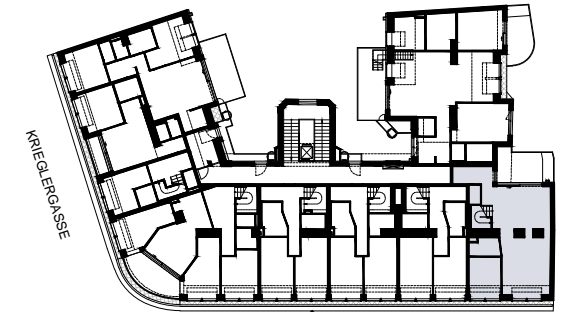

EINGANG
UNTERE WEISSGERBERSTRASSE

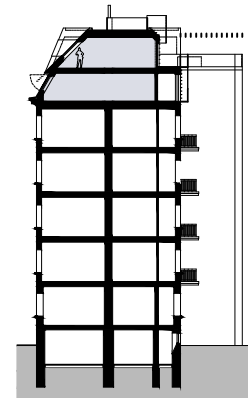

TOP 25

1. + 2. DACHGESCHOSS 3 ZIMMER

Wohnung ca. 114,15m²

Terrasse ca. 8.50m²
Loggia / Balkon ca. 11.39m²
Raumhöhe 1.DG ca. 2,52m
Raumhöhe 2.DG ca. 2,75m

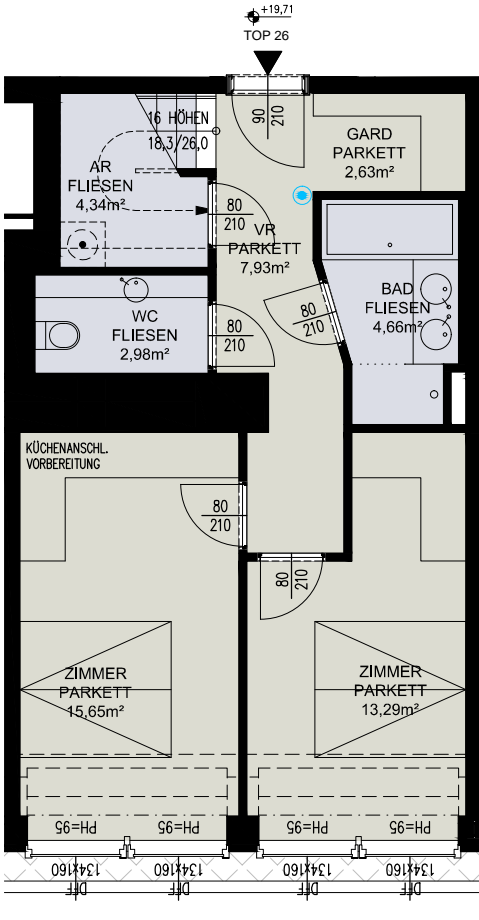

1.DG

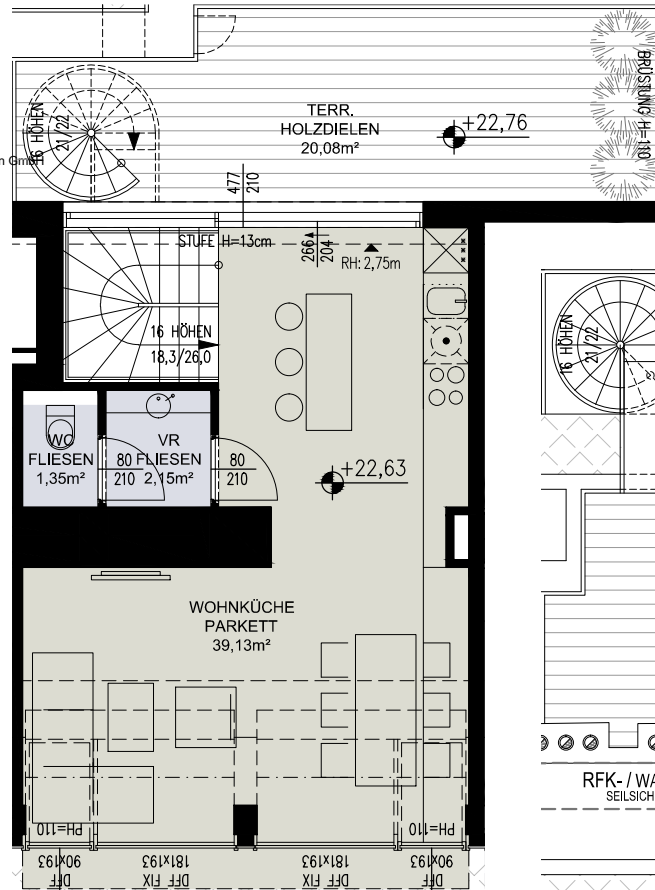

2.DG

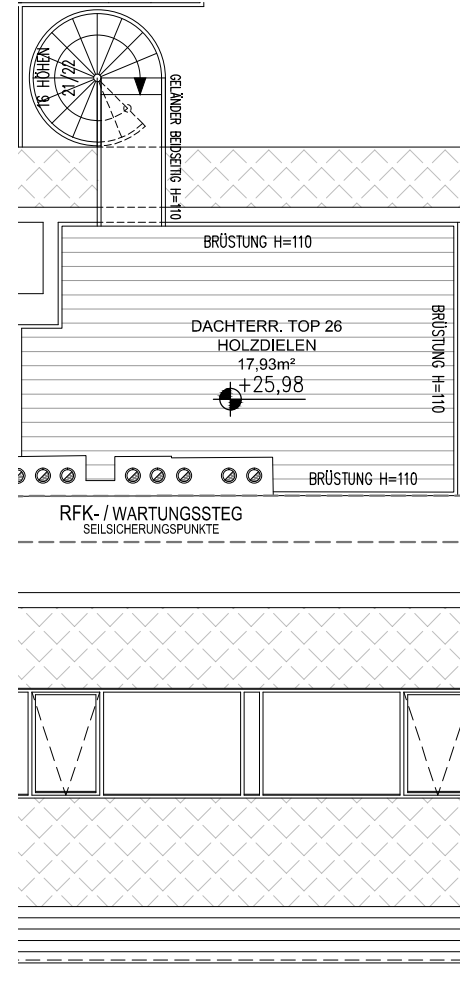

DACH

UNTERE WEISSGERBERSTRASSE 17
A-1030 Wien

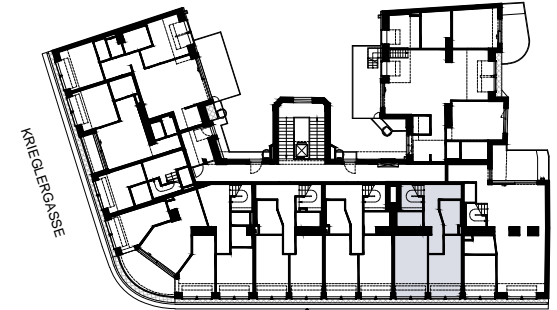

EINGANG
UNTERE WEISSGERBERSTRASSE

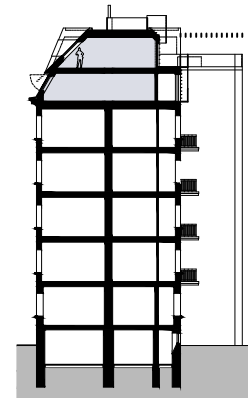

TOP 26

1. + 2. DACHGESCHOSS 3 ZIMMER

Wohnung ca. 94,11m²

Terrasse ca. 20.08m²

Dachterrasse ca. 17.93m²

Raumhöhe 1.DG ca. 2,52m

Raumhöhe 2.DG ca. 2,75m

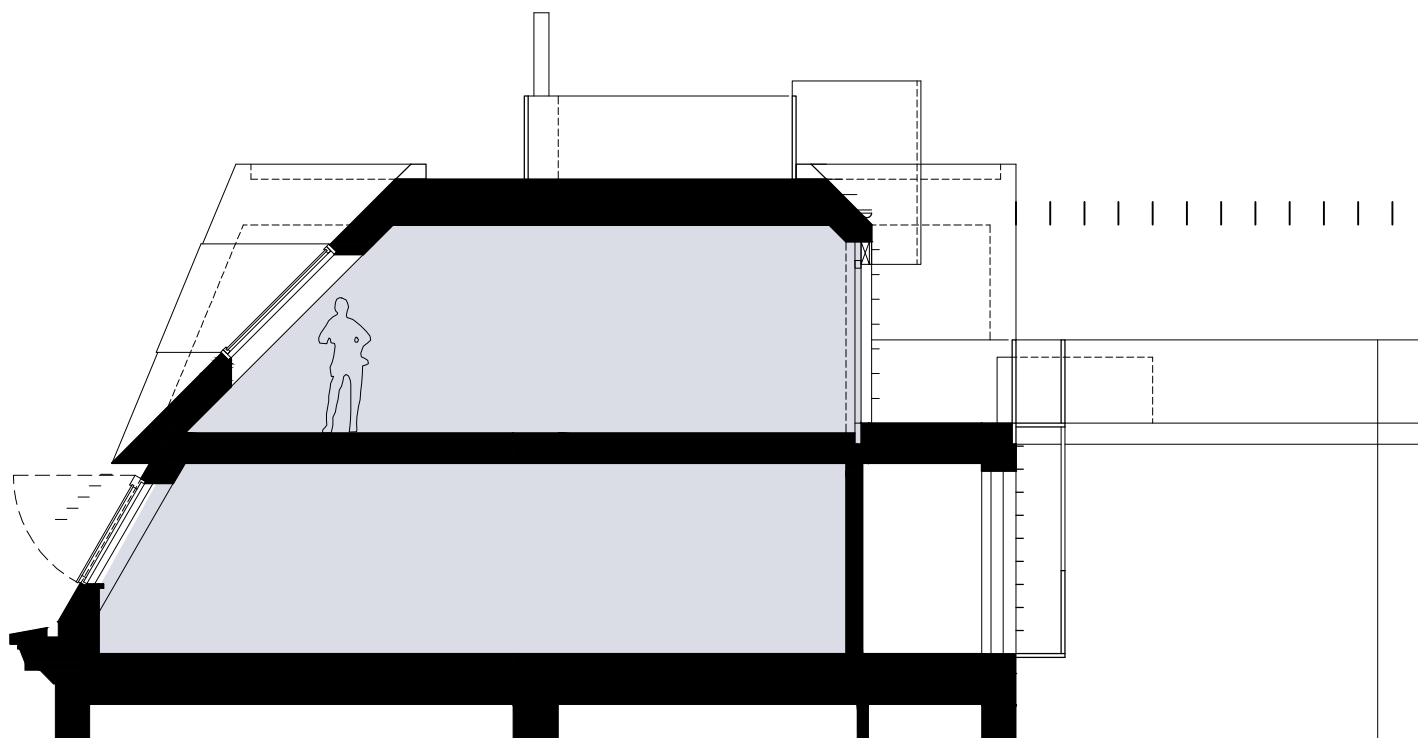

SCHNITT

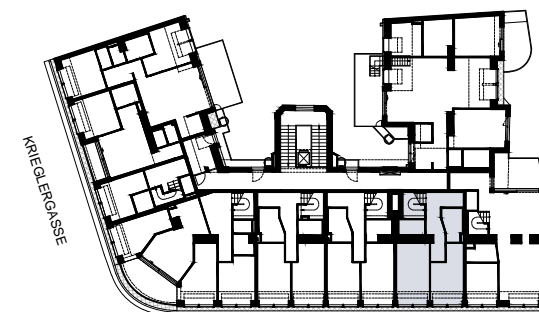

EINGANG
UNTERE WEISSGERBERSTRASSE

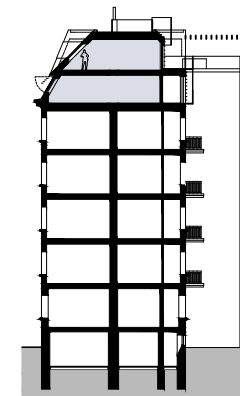

TOP 26

1. + 2. DACHGESCHOSS 3 ZIMMER

Wohnung ca. 94,11m²

Terrasse ca. 20.08m²

Dachterrasse ca. 17.93m²

Raumhöhe 1.DG ca. 2,52m

Raumhöhe 2.DG ca. 2,75m

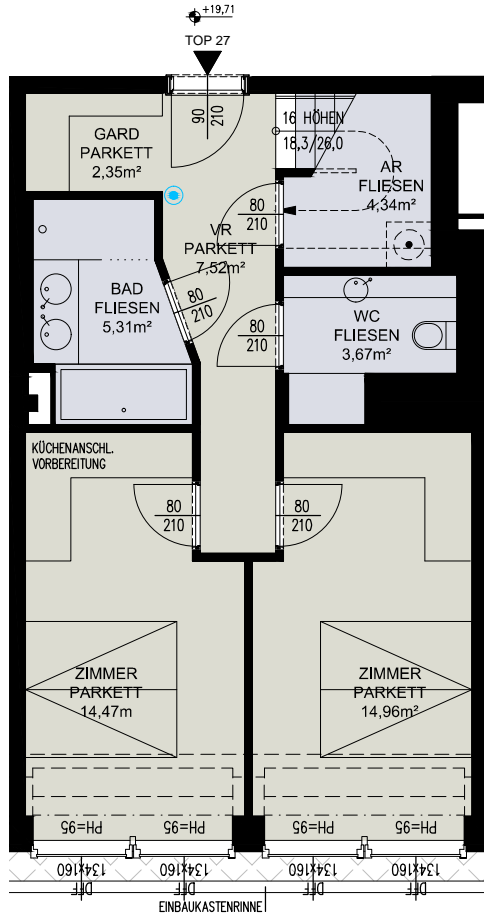

1.DG

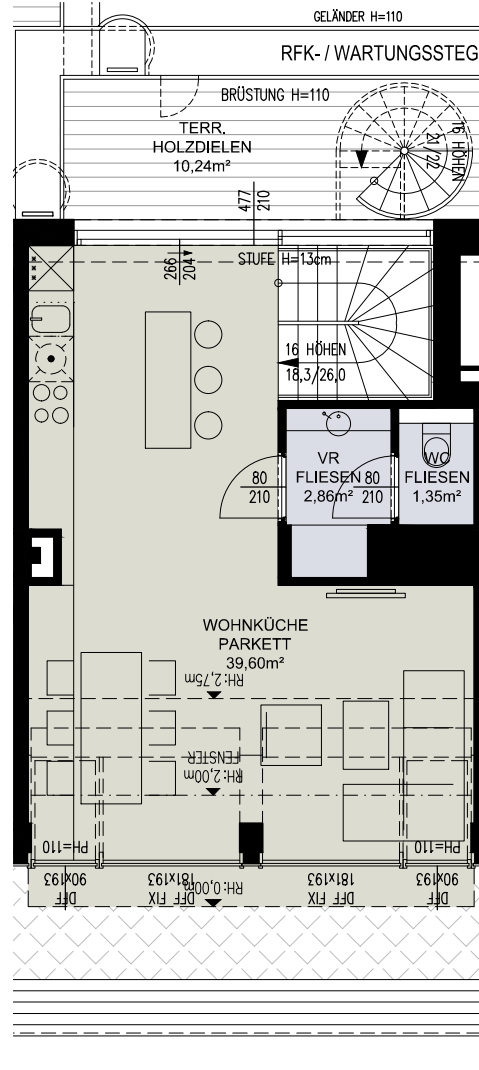

2.DG

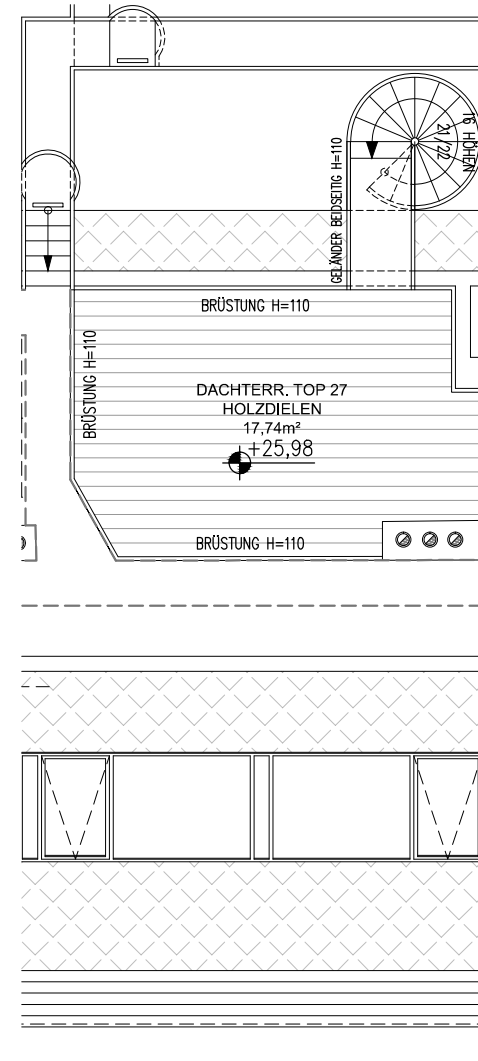

DACH

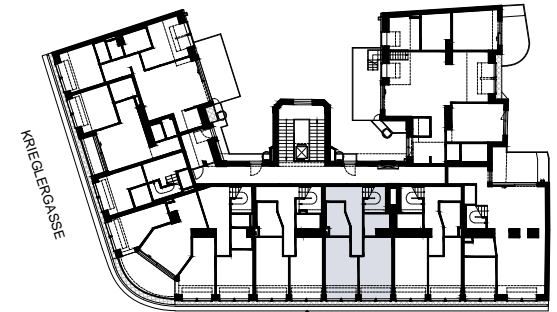

EINGANG
UNTERE WEISSGERBERSTRASSE

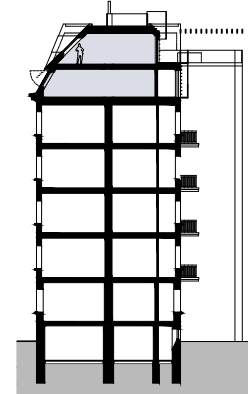

TOP 27

1. + 2. DACHGESCHOSS 3 ZIMMER

Wohnung ca. 96,43m²

Terrasse ca. 10,24m²

Dachterrasse ca. 17,74m²

Raumhöhe 1.DG ca. 2,52m

Raumhöhe 2.DG ca. 2,75m

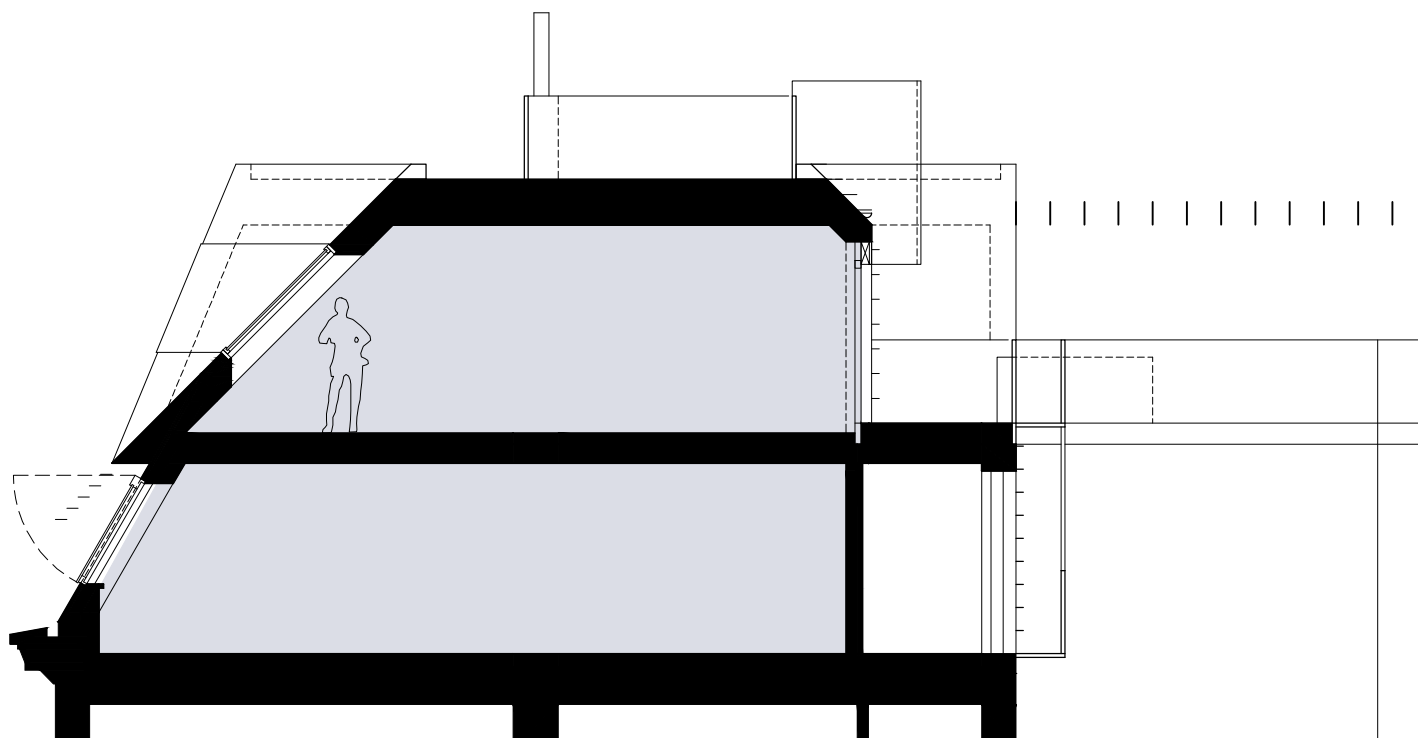

SCHNITT

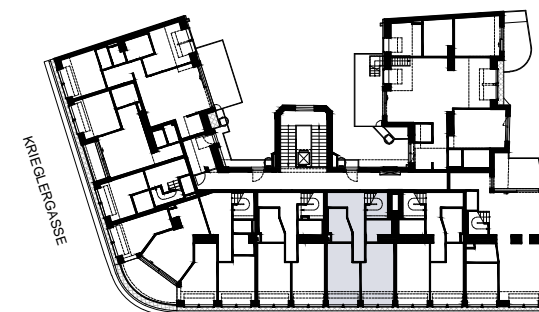

EINGANG
UNTERE WEISSGERBERSTRASSE

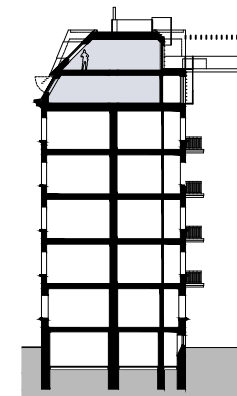

TOP 27

1. + 2. DACHGESCHOSS 3 ZIMMER

Wohnung ca. 96,43m²

Terrasse ca. 10,24m²

Dachterrasse ca. 17,74m²

Raumhöhe 1.DG ca. 2,52m

Raumhöhe 2.DG ca. 2,75m

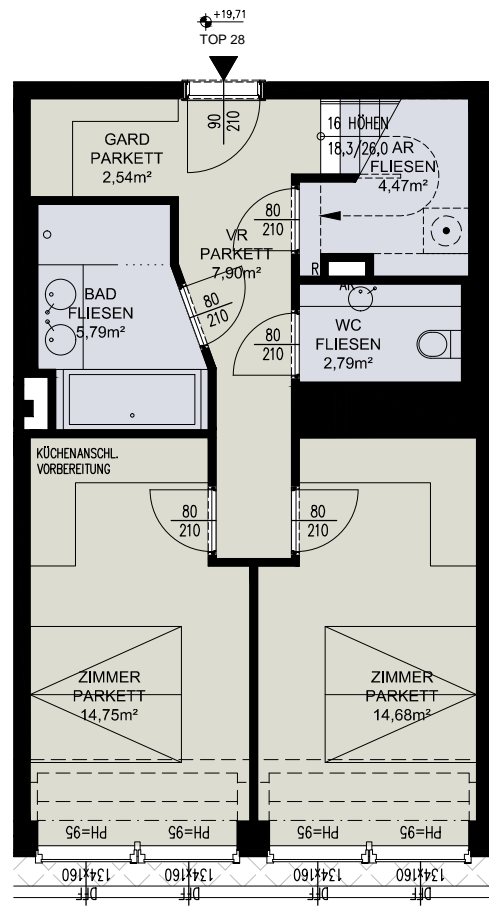

1.DG

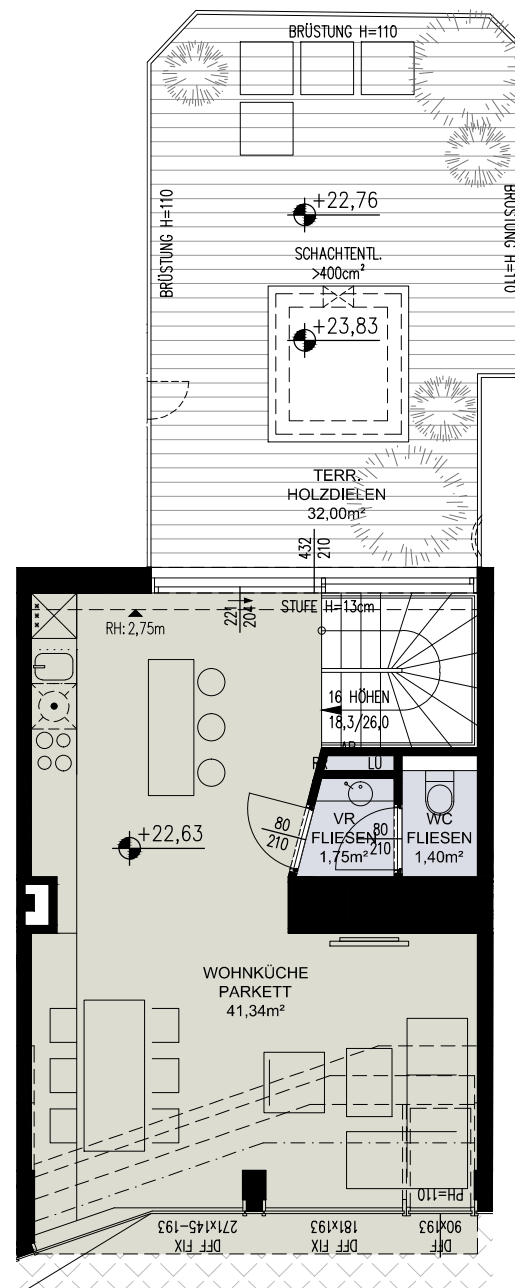

2.DG

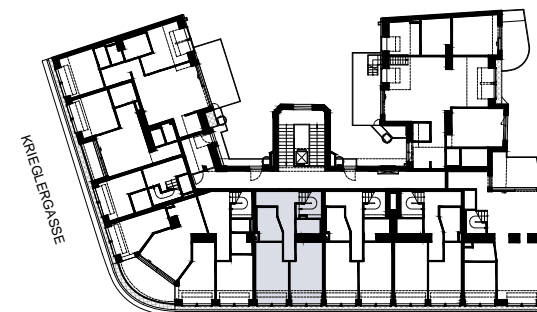

EINGANG
UNTERE WEISSGERBERSTRASSE

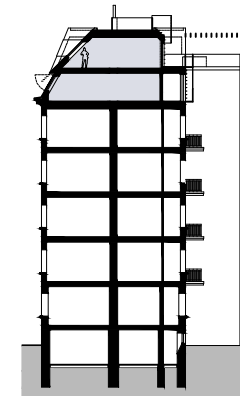

TOP 28

1. + 2. DACHGESCHOSS 3 ZIMMER

Wohnung ca. 97,41m²

Terrasse ca. 32,00m²

Raumhöhe 1.DG ca. 2,52m

Raumhöhe 2.DG ca. 2,75m

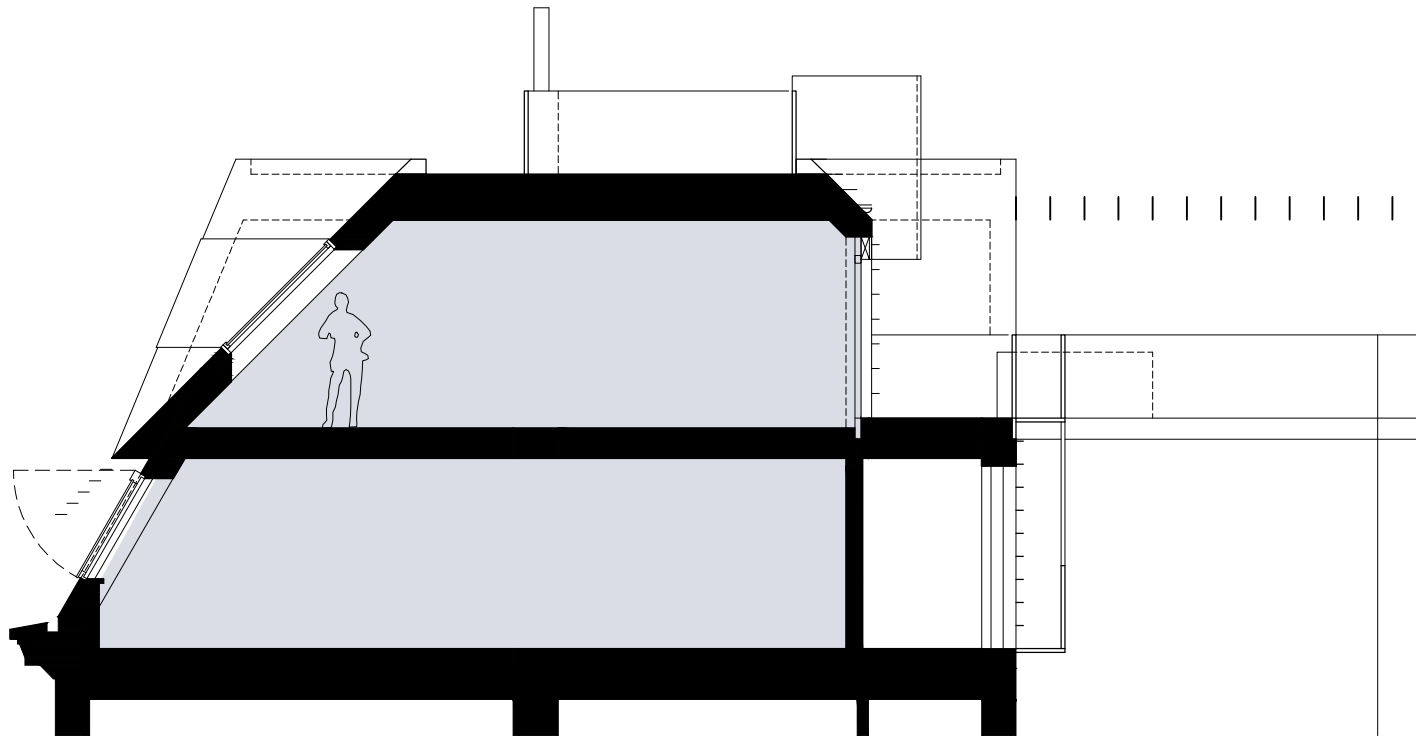

SCHNITT

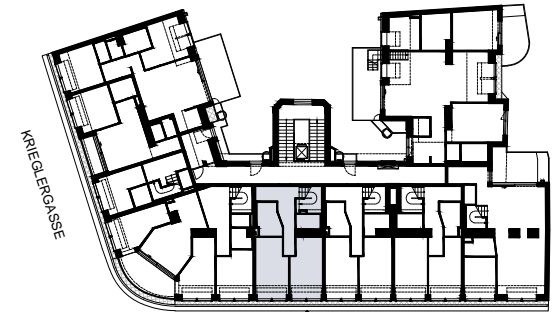

EINGANG
UNTERE WEISSGERBERSTRASSE

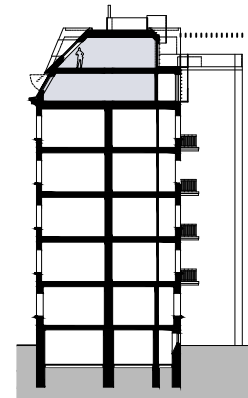

TOP 28

1. + 2. DACHGESCHOSS 3 ZIMMER

Wohnung ca. 97,41m²

Terrasse ca. 32.00m²

Raumhöhe 1.DG ca. 2,52m

Raumhöhe 2.DG ca. 2,75m

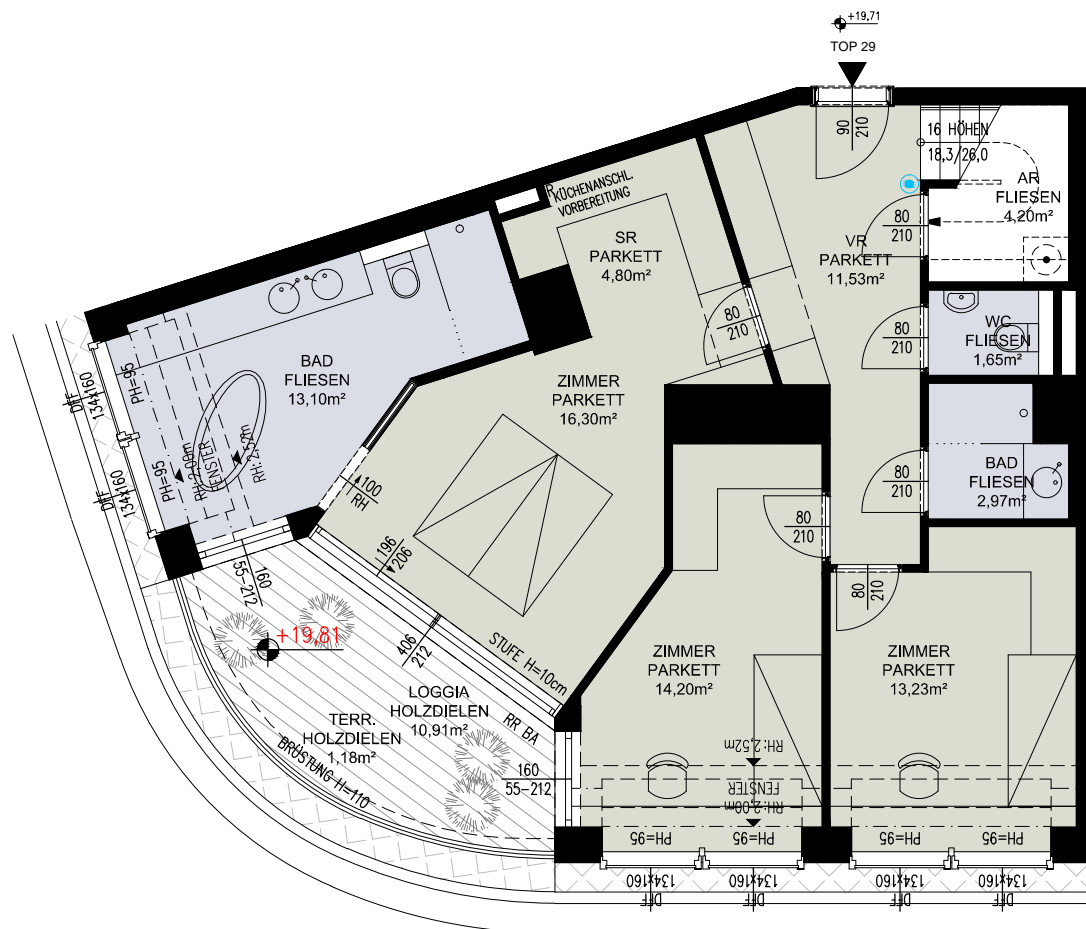

1.DG

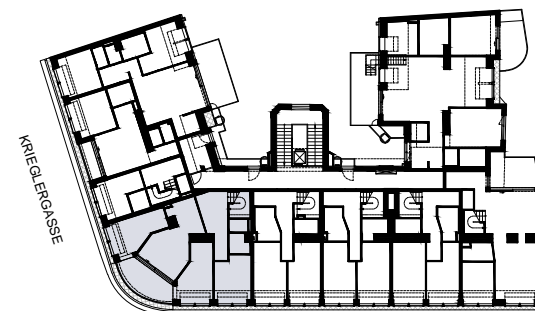

EINGANG
UNTERE WEISSGERBERSTRASSE

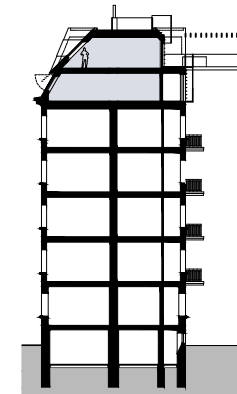

TOP 29

1. + 2. DACHGESCHOSS 4 ZIMMER

Wohnung	ca.	151,61m ²
Loggia / Terrasse	ca.	12,09m ²
Terrasse 1	ca.	10,72m ²
Terrasse 2	ca.	10,86m ²
Dachterrasse	ca.	54,25m ²
Raumhöhe 1.DG	ca.	2,52m
Raumhöhe 2.DG	ca.	2,75m

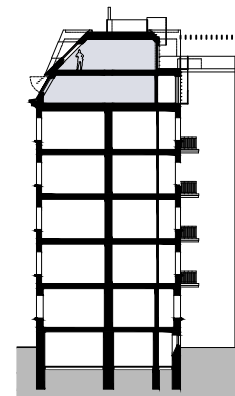
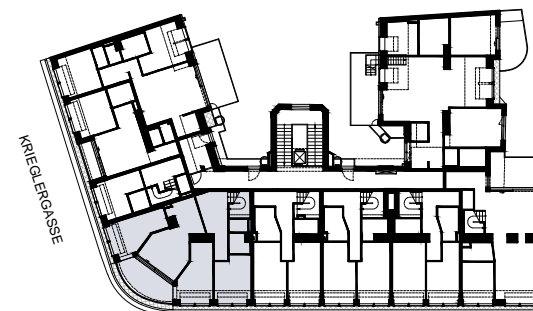
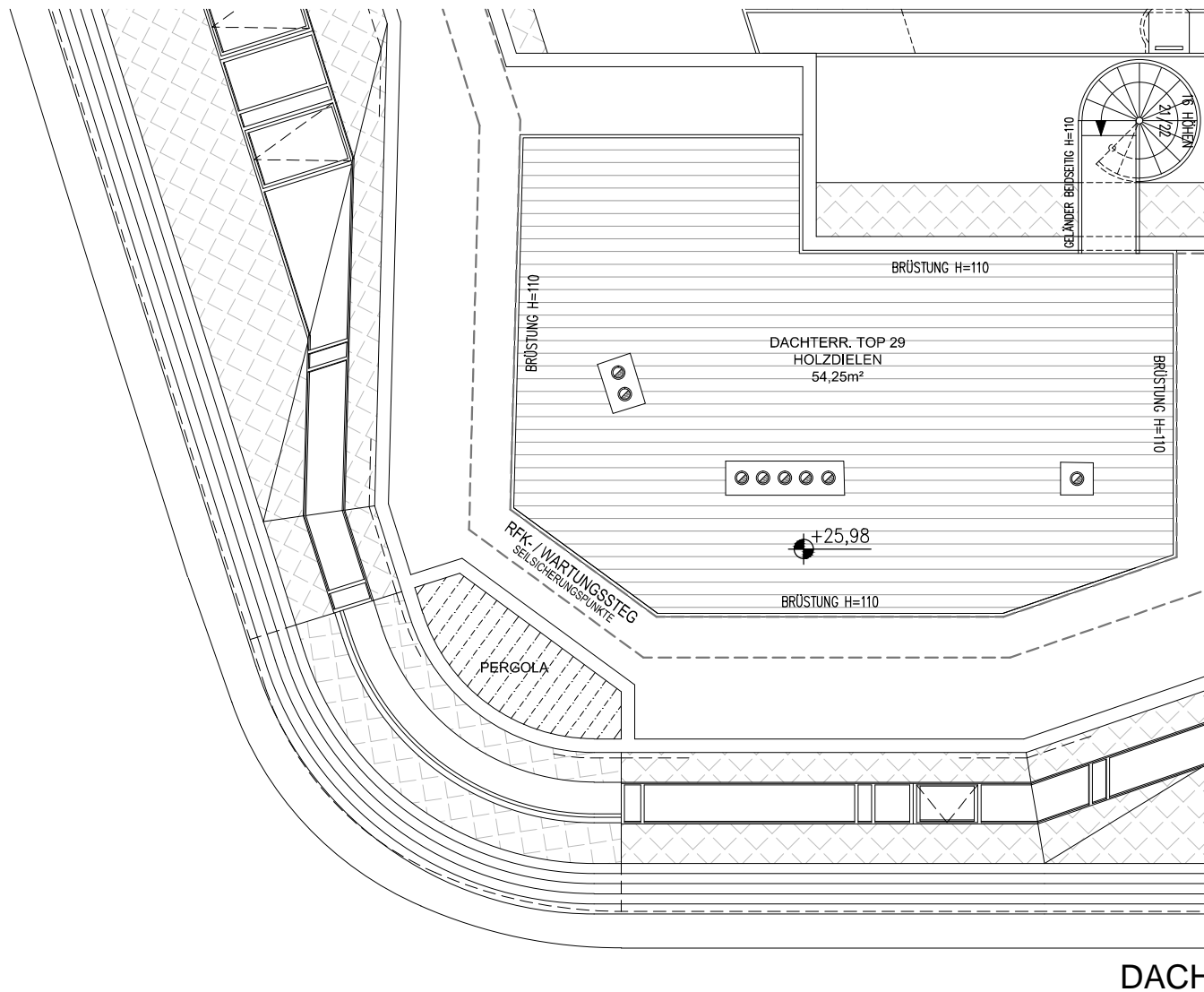

TOP 29

1. + 2. DACHGESCHOSS 4 ZIMMER

Wohnung	ca.	151,61m ²
Loggia / Terrasse	ca.	12,09m ²
Terrasse 1	ca.	10,72m ²
Terrasse 2	ca.	10,86m ²
Dachterrasse	ca.	54,25m ²
Raumhöhe 1.DG	ca.	2,52m
Raumhöhe 2.DG	ca.	2,75m

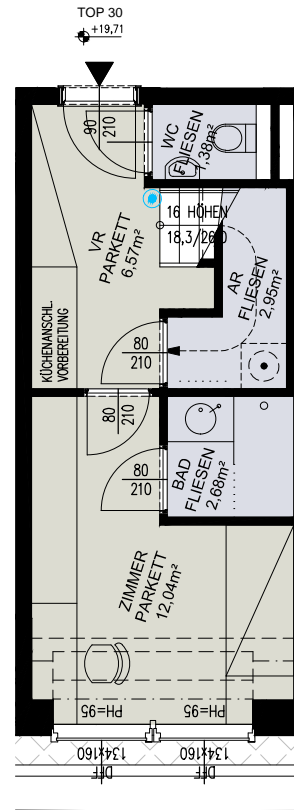
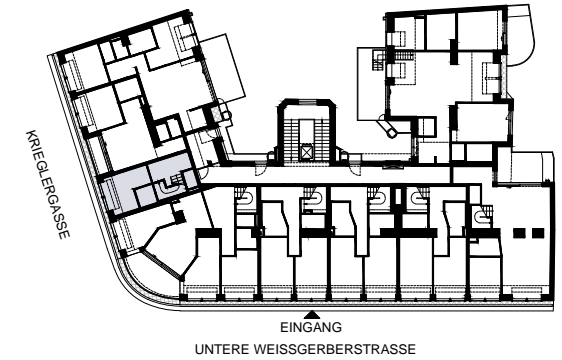

1.DG

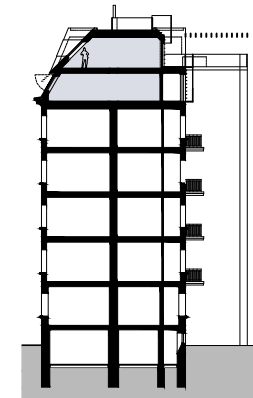

TOP 30

1. + 2. DACHGESCHOSS 4 ZIMMER

Wohnung ca. 131,75m²

Terrasse ca. 11.21m²

Dachterrasse ca. 19.70m²

Raumhöhe 1.DG ca. 2,52m

Raumhöhe 2.DG ca. 2,75m

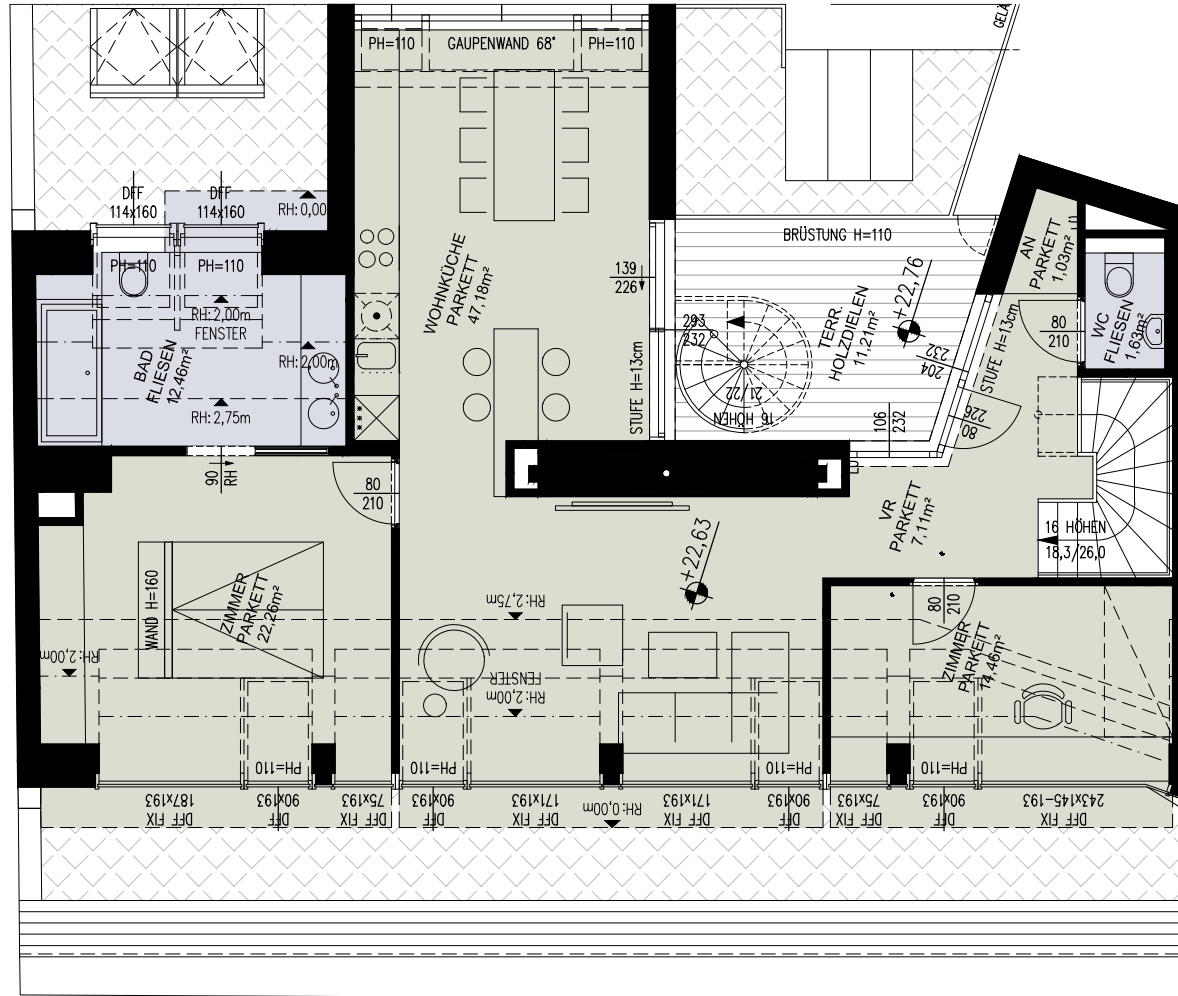

2.DG

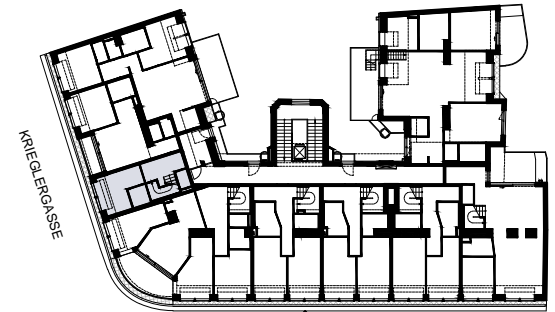

EINGANG
UNTERE WEISSGERBERSTRASSE

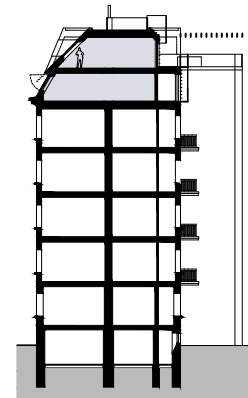

TOP 30

1. + 2. DACHGESCHOSS 4 ZIMMER

Wohnung ca. 131,75m²

Terrasse ca. 11.21m²

Dachterrasse ca. 19.70m²

Raumhöhe 1.DG ca. 2,52m

Raumhöhe 2.DG ca. 2,75m

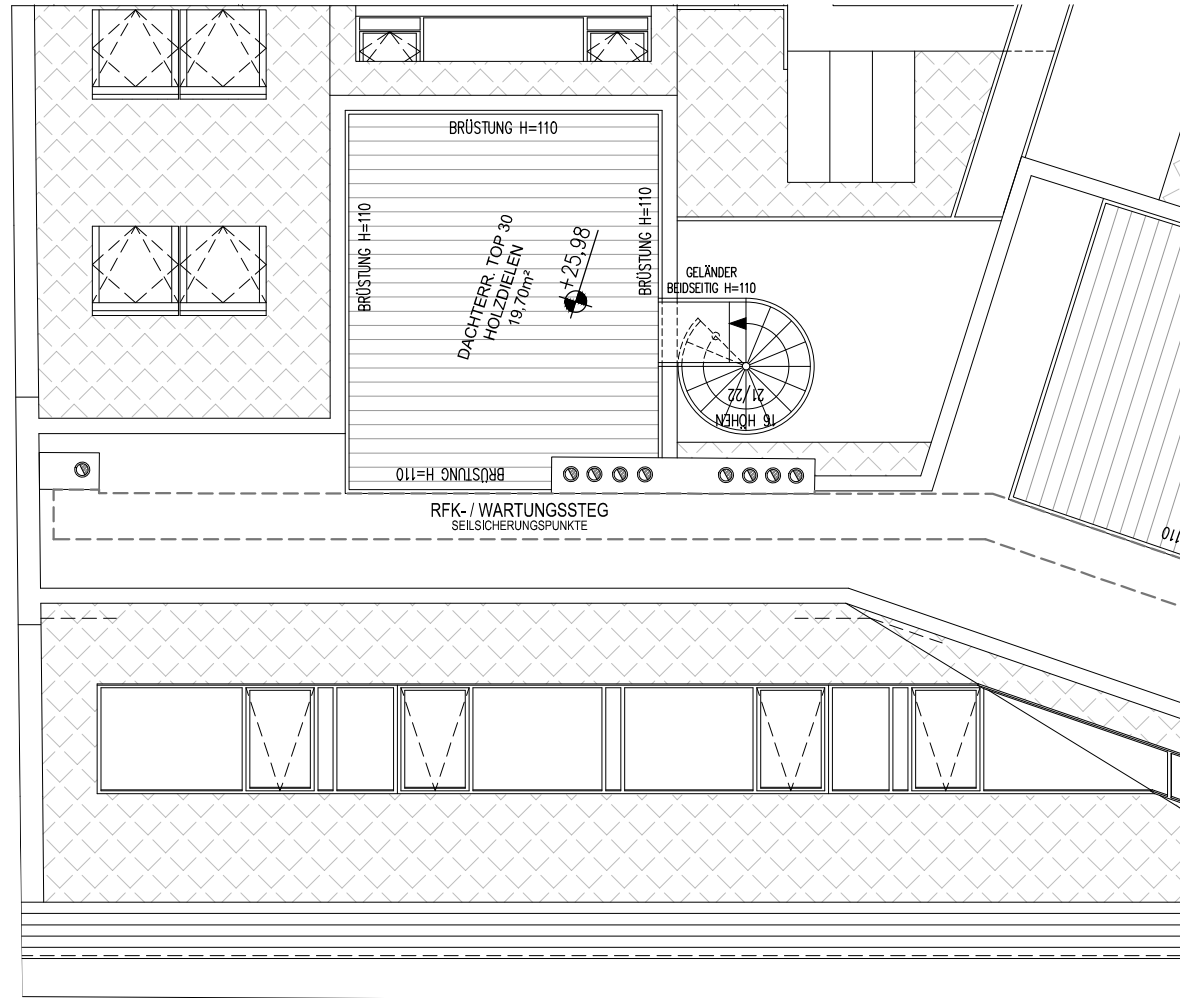

DACH

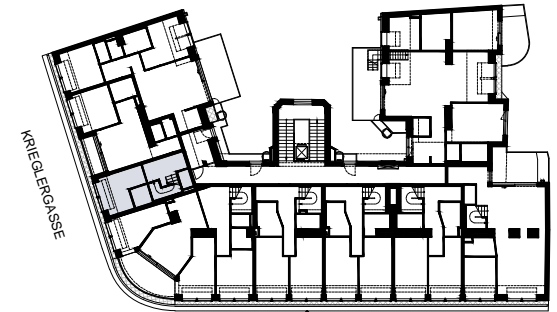

EINGANG
UNTERE WEISSGERBERSTRASSE

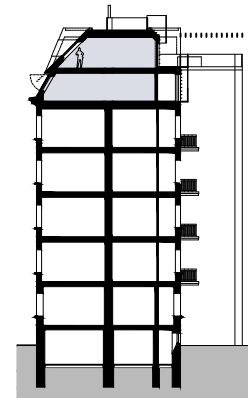

TOP 30

1. + 2. DACHGESCHOSS 4 ZIMMER

Wohnung ca. 131,75m²

Terrasse ca. 11,21m²

Dachterrasse ca. 19,70m²

Raumhöhe 1.DG ca. 2,52m

Raumhöhe 2.DG ca. 2,75m

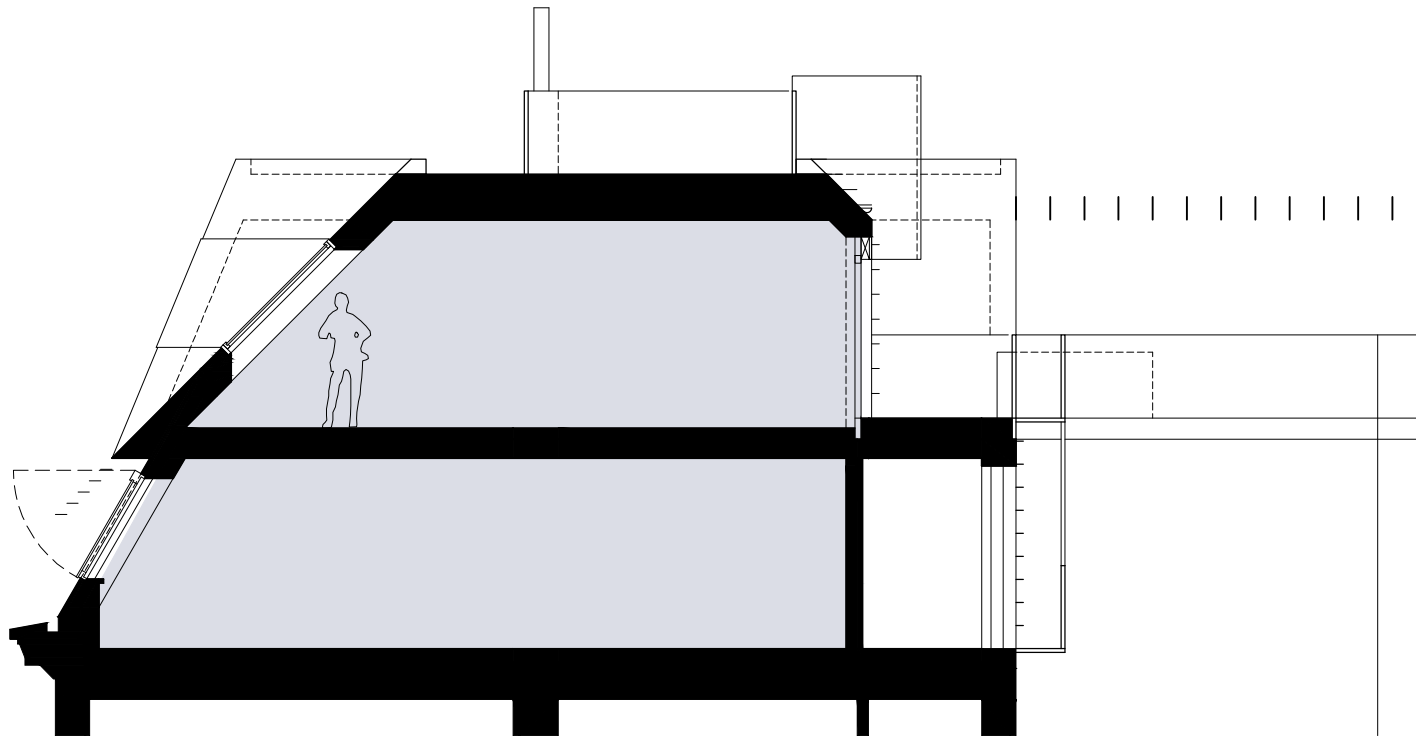

SCHNITT

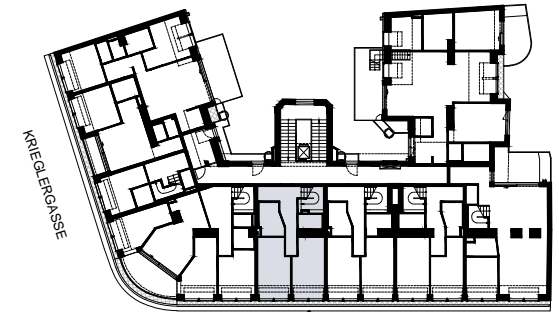

EINGANG
UNTERE WEISSGERBERSTRASSE

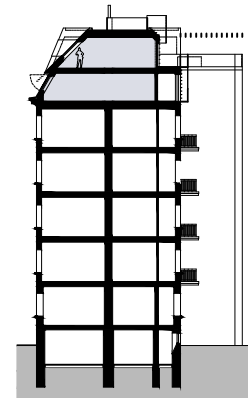

TOP 30

1. + 2. DACHGESCHOSS 4 ZIMMER

Wohnung ca. 131,75m²

Terrasse ca. 11.21m²

Dachterrasse ca. 19.70m²

Raumhöhe 1.DG ca. 2,52m

Raumhöhe 2.DG ca. 2,75m

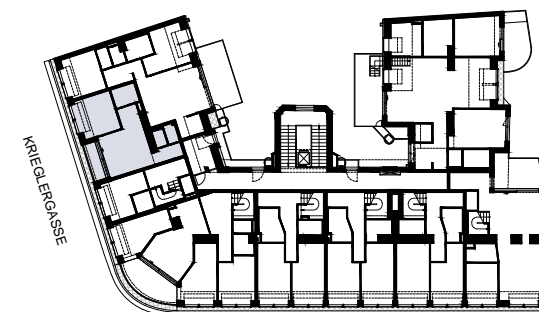
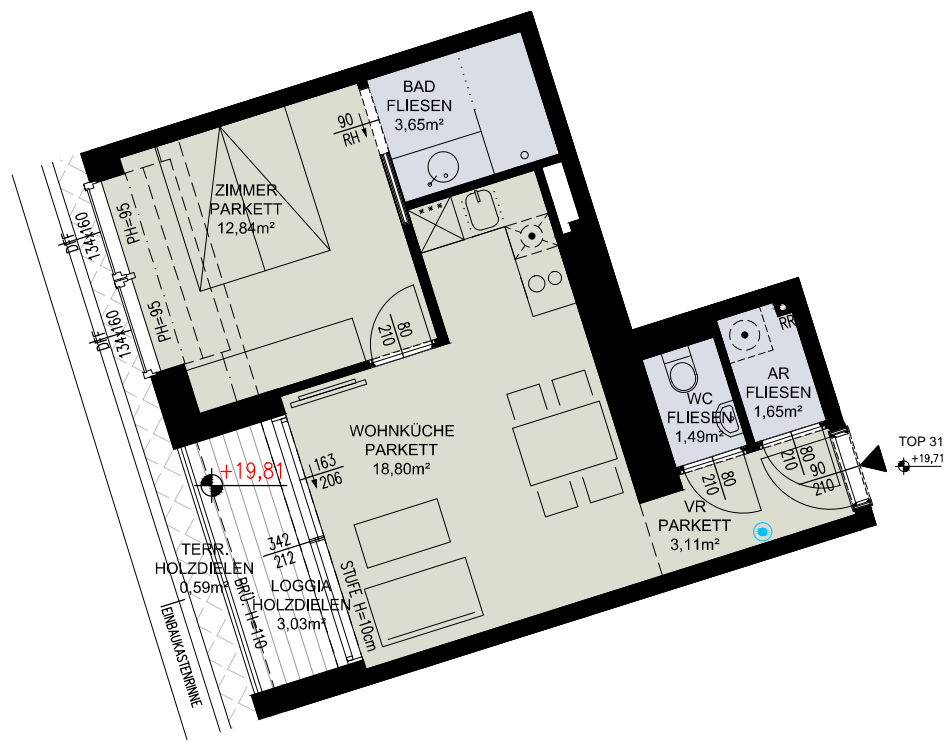

EINGANG
UNTERE WEISSGERBERSTRASSE

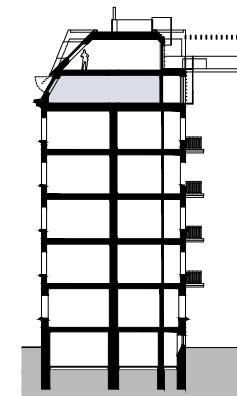

TOP 31

1. DACHGESCHOSS 2 ZIMMER

Wohnung ca. 41,54m²

Loggia / Terrasse ca. 3,62m²

Raumhöhe 1.DG ca. 2,52m

1.DG

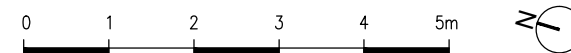

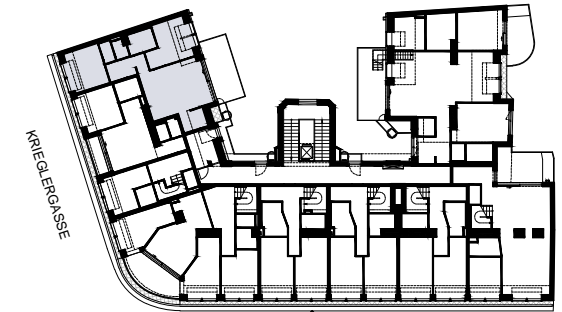
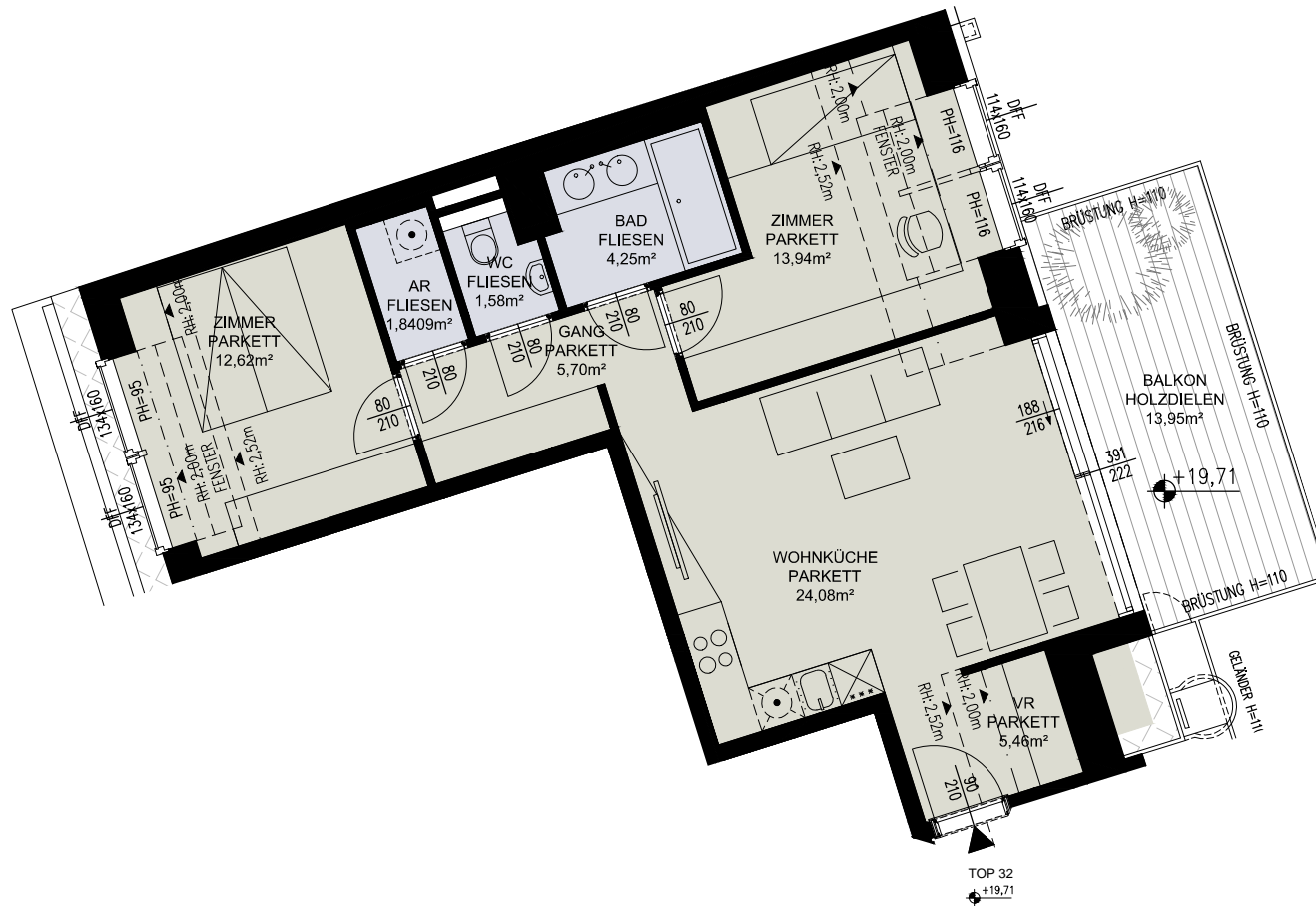

EINGANG
UNTERE WEISSGERBERSTRASSE

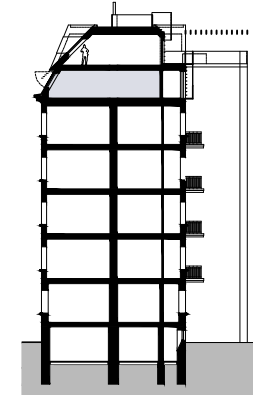

TOP 32

1. DACHGESCHOSS 3 ZIMMER

Wohnung ca. 69,47m²

Balkon ca. 13,95m²
Raumhöhe ca. 2,52m

1.DG

